

# Particle Physics

# The Standard Model

Antonio Pich

IFIC, CSIC – Univ. Valencia

[Antonio.Pich@cern.ch](mailto:Antonio.Pich@cern.ch)

# 4. QUANTUM CHROMODYNAMICS

- QCD Lagrangian
- Running Coupling
- Asymptotic Freedom
- $\alpha_s$  Measurements



# QUANTUM CHROMODYNAMICS

FREE QUARKS:  $N_c = 3$

$$\mathcal{L} = \bar{\mathbf{q}} [i \gamma^\mu \partial_\mu - m] \mathbf{q}$$

$$\mathbf{q} \equiv \begin{pmatrix} q \\ q \\ q \end{pmatrix}$$

SU(3) Colour Symmetry:

$$\mathbf{q} \rightarrow \mathbf{U} \mathbf{q} \quad ; \quad \bar{\mathbf{q}} \rightarrow \bar{\mathbf{q}} \mathbf{U}^\dagger$$

$$\mathbf{U} \mathbf{U}^\dagger = \mathbf{U}^\dagger \mathbf{U} = \mathbf{1} \quad ; \quad \det \mathbf{U} = 1$$

# ABELIAN ROTATIONS

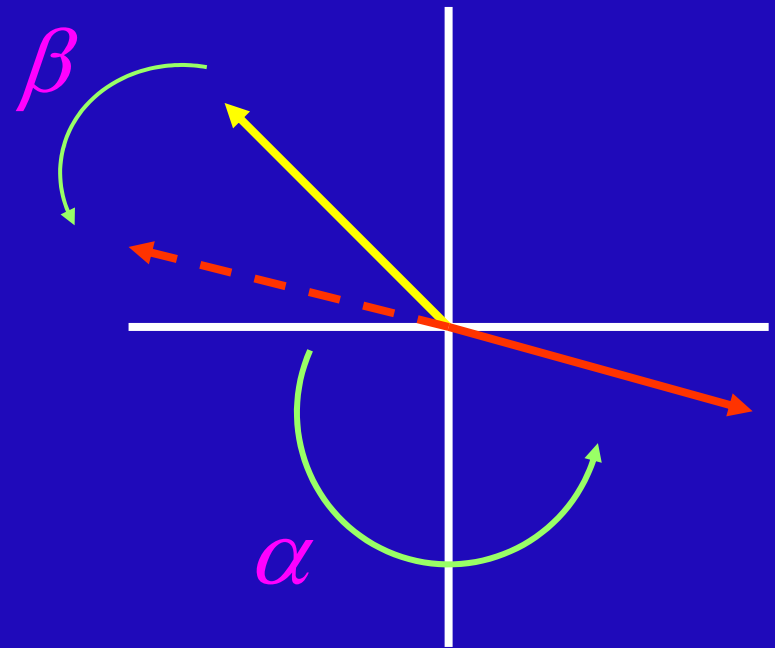
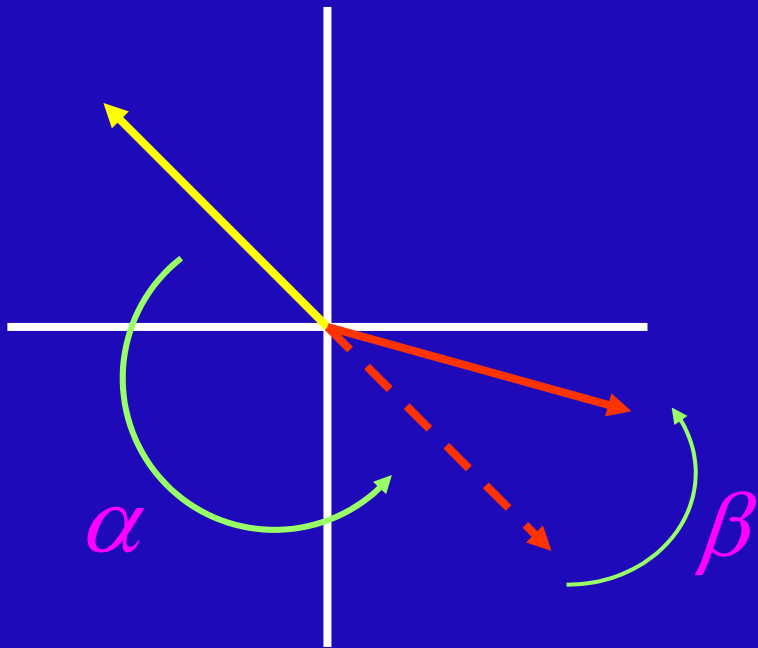

# NON ABELIAN ROTATIONS

$$AB - BA = C$$

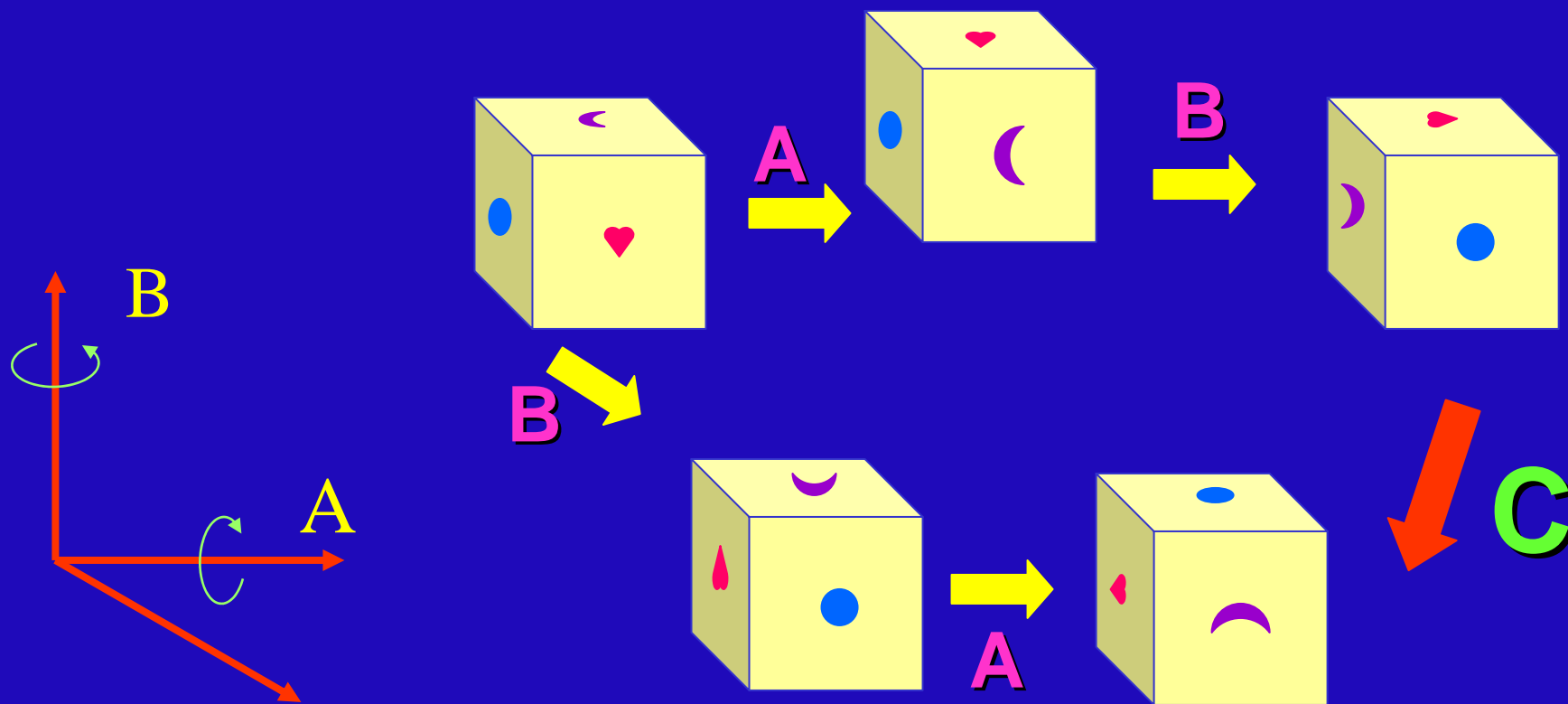

# SU(N) ALGEBRA

$N \times N$  matrices:  $\mathbf{U} \mathbf{U}^\dagger = \mathbf{U}^\dagger \mathbf{U} = \mathbf{1}$  ;  $\det \mathbf{U} = 1$

$$\mathbf{U} = \exp \left\{ i \mathbf{T}^a \theta_a \right\} ; \quad \mathbf{T}^a = \mathbf{T}^{a\dagger} ; \quad \text{Tr}(\mathbf{T}^a) = 0 ; \quad a = 1, \dots, N^2 - 1$$

**Commutation Relation:**  $[\mathbf{T}^a, \mathbf{T}^b] = i f^{abc} \mathbf{T}^c$

Structure Constants  $f^{abc}$  real, antisymmetric

**Fundamental Representation:**  $\mathbf{T}_F^a = \frac{1}{2} \lambda^a$   $N \times N$

**Adjoint Representation:**  $(\mathbf{T}_A^a)_{bc} = -i f^{abc}$   $(N^2 - 1) \times (N^2 - 1)$

$$\text{Tr}(\mathbf{T}_F^a \mathbf{T}_F^b) = T_F \delta_{ab} ; \quad \text{Tr}(\mathbf{T}_A^a \mathbf{T}_A^b) = C_A \delta_{ab} ; \quad (\mathbf{T}_F^a \mathbf{T}_F^a)_{\alpha\beta} = C_F \delta_{\alpha\beta}$$

$$T_F = \frac{1}{2} ; \quad C_A = N ; \quad C_F = \frac{N^2 - 1}{2N}$$

# SU(2)

$2 \times 2$  matrices:  $\mathbf{U} \mathbf{U}^\dagger = \mathbf{U}^\dagger \mathbf{U} = \mathbf{1}$  ;  $\det \mathbf{U} = 1$

$\mathbf{U} = \exp \left\{ i \mathbf{T}^a \theta_a \right\}$  ;  $\mathbf{T}^a = \mathbf{T}^{a\dagger}$  ;  $\text{Tr}(\mathbf{T}^a) = 0$  ;  $a = 1, \dots, 3$

**Commutation Relation:**  $[\mathbf{T}^a, \mathbf{T}^b] = i \varepsilon^{abc} \mathbf{T}^c$

**Fundamental Representation:**

$$\mathbf{T}_F^a = \frac{1}{2} \sigma^a$$

**Pauli**

$$\sigma^1 = \begin{pmatrix} 0 & 1 \\ 1 & 0 \end{pmatrix} ; \quad \sigma^2 = \begin{pmatrix} 0 & -i \\ i & 0 \end{pmatrix} ; \quad \sigma^3 = \begin{pmatrix} 1 & 0 \\ 0 & -1 \end{pmatrix}$$

# SU(3)

$$[T^a, T^b] = i f^{abc} T^c$$

**Fundamental Representation:**

$$\mathbf{T}_F^a = \frac{1}{2} \lambda^a$$

Gell-Mann

$$\lambda^1 = \begin{pmatrix} 0 & 1 & 0 \\ 1 & 0 & 0 \\ 0 & 0 & 0 \end{pmatrix} ; \quad \lambda^2 = \begin{pmatrix} 0 & -i & 0 \\ i & 0 & 0 \\ 0 & 0 & 0 \end{pmatrix} ; \quad \lambda^3 = \begin{pmatrix} 1 & 0 & 0 \\ 0 & -1 & 0 \\ 0 & 0 & 0 \end{pmatrix} ; \quad \lambda^4 = \begin{pmatrix} 0 & 0 & 1 \\ 0 & 0 & 0 \\ 1 & 0 & 0 \end{pmatrix}$$

$$\lambda^5 = \begin{pmatrix} 0 & 0 & -i \\ 0 & 0 & 0 \\ i & 0 & 0 \end{pmatrix} ; \quad \lambda^6 = \begin{pmatrix} 0 & 0 & 0 \\ 0 & 0 & 1 \\ 0 & 1 & 0 \end{pmatrix} ; \quad \lambda^7 = \begin{pmatrix} 0 & 0 & 0 \\ 0 & 0 & -i \\ 0 & i & 0 \end{pmatrix} ; \quad \lambda^8 = \frac{1}{\sqrt{3}} \begin{pmatrix} 1 & 0 & 0 \\ 0 & 1 & 0 \\ 0 & 0 & -2 \end{pmatrix}$$

$$\frac{1}{2} f^{123} = f^{147} = -f^{156} = f^{246} = f^{257} = f^{345} = -f^{367} = \frac{1}{\sqrt{3}} f^{458} = \frac{1}{\sqrt{3}} f^{678} = \frac{1}{2}$$



# QUANTUM CHROMODYNAMICS

FREE QUARKS:

$$N_c = 3$$

$$\mathbf{q} \equiv \begin{pmatrix} q \\ q \\ q \end{pmatrix}$$

$$\mathcal{L} = \bar{\mathbf{q}} [i \gamma^\mu \partial_\mu - m] \mathbf{q}$$

SU(3) Colour Symmetry:

$$\mathbf{q} \rightarrow \mathbf{U} \mathbf{q} = \exp \left\{ i \frac{\lambda^a}{2} \theta_a \right\} \mathbf{q}$$

Gauge Principle:

Local Symmetry

$$\theta_a = \theta_a(x)$$

$$\mathbf{D}^\mu \mathbf{q} \equiv (\mathbf{I}_3 \partial^\mu - i g_s \mathbf{G}^\mu) \mathbf{q} \rightarrow \mathbf{U} \mathbf{D}^\mu \mathbf{q}$$

$$\mathbf{D}^\mu \rightarrow \mathbf{U} \mathbf{D}^\mu \mathbf{U}^\dagger$$

;

$$\mathbf{G}^\mu \rightarrow \mathbf{U} \mathbf{G}^\mu \mathbf{U}^\dagger - \frac{i}{g_s} (\partial^\mu \mathbf{U}) \mathbf{U}^\dagger$$

$$[\mathbf{G}^\mu]_{\alpha\beta} \equiv \frac{1}{2} (\lambda^a)_{\alpha\beta} G_a^\mu(x)$$

**8 Gluon Fields**

## Infinitesimal SU(3) Transformation:

$$\delta q^\alpha = i \delta\theta_a \left( \frac{\lambda^a}{2} \right)_{\alpha\beta} q^\beta \quad ; \quad \delta G_a^\mu = \frac{1}{g_s} \partial^\mu (\delta\theta_a) - f^{abc} \delta\theta_b G_c^\mu$$

Non Abelian Group:

$$f^{abc} \neq 0$$

- $\delta G_a^\mu$  depends on  $G_a^\mu$
- Universal  $g_s$
- No Colour Charges

## Kinetic Term:

$$\mathbf{G}^{\mu\nu} \equiv \frac{i}{g_s} [\mathbf{D}^\mu, \mathbf{D}^\nu] = \partial^\mu \mathbf{G}^\nu - \partial^\nu \mathbf{G}^\mu - i g_s [\mathbf{G}^\mu, \mathbf{G}^\nu] \rightarrow \mathbf{U} \mathbf{G}^{\mu\nu} \mathbf{U}^\dagger$$

$$\mathbf{G}^{\mu\nu} \equiv \frac{\lambda^a}{2} G_a^{\mu\nu} \quad ; \quad G_a^{\mu\nu} = \partial^\mu G_a^\nu - \partial^\nu G_a^\mu + g_s f^{abc} G_b^\mu G_c^\nu$$

$$\mathcal{L}_K = -\frac{1}{2} \text{Tr} (\mathbf{G}^{\mu\nu} \mathbf{G}_{\mu\nu}) = -\frac{1}{4} G_a^{\mu\nu} G_{\mu\nu}^a$$

## Mass Term:

$$\mathcal{L}_M = \frac{1}{2} m_G^2 G_a^\mu G_\mu^a$$

Not Gauge Invariant



$$m_G = 0$$

# Massless Gluons

$$\begin{aligned}
\mathcal{L}_{\text{QCD}} &= -\frac{1}{2} \text{Tr} (\mathbf{G}^{\mu\nu} \mathbf{G}_{\mu\nu}) + \bar{\mathbf{q}} [i \gamma^\mu \mathbf{D}_\mu - m_q] \mathbf{q} \\
&= -\frac{1}{4} (\partial^\mu G_\nu^a - \partial_\nu G_\mu^a) (\partial_\mu G_\nu^a - \partial_\nu G_\mu^a) + \sum_q \bar{q}_\alpha [i \gamma^\mu \partial_\mu - m_q] q_\alpha \\
&+ \frac{1}{2} \sum_q g_s [\bar{q}_\alpha (\lambda^a)_{\alpha\beta} \gamma^\mu q_\beta] G_\mu^a \\
&- \frac{1}{2} g_s f_{abc} (\partial_\mu G_\nu^a - \partial_\nu G_\mu^a) G_b^\mu G_c^\nu - \frac{1}{4} g_s^2 f_{abc} f_{ade} G_b^\mu G_c^\nu G_\mu^d G_\nu^e
\end{aligned}$$

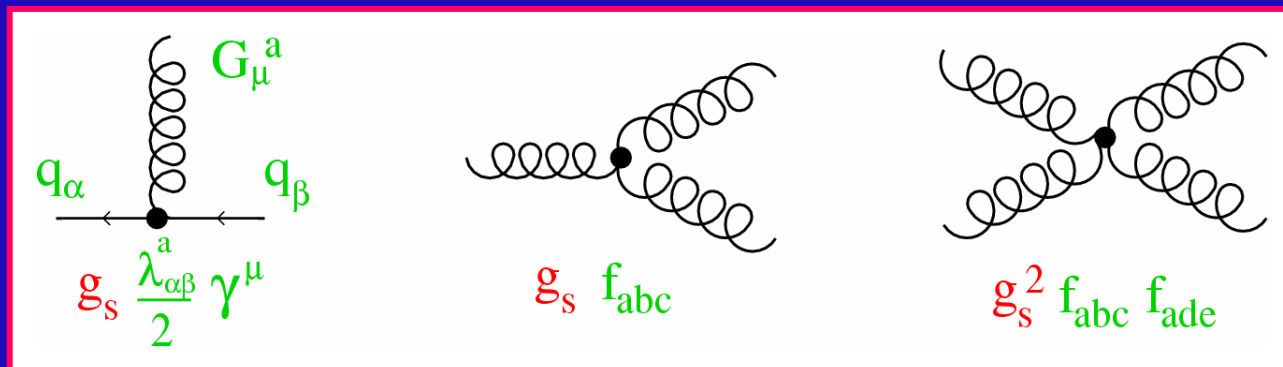

▪ **Gluon Self – interactions**

$\mathbf{G}^3$  ,  $\mathbf{G}^4$

▪ **Universal Coupling**  $g_s$

**(No Colour Charges)**

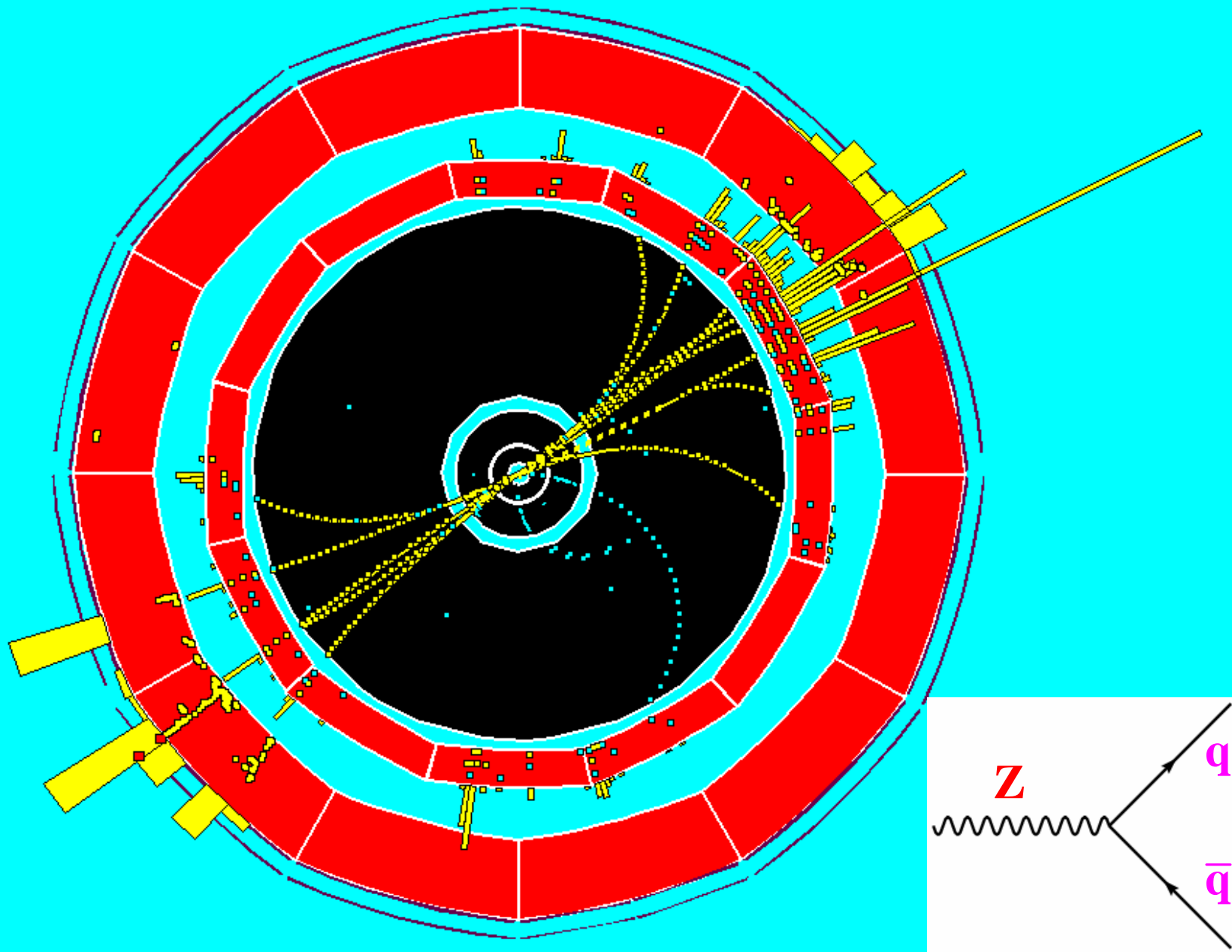

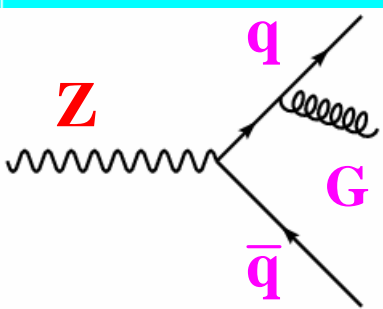
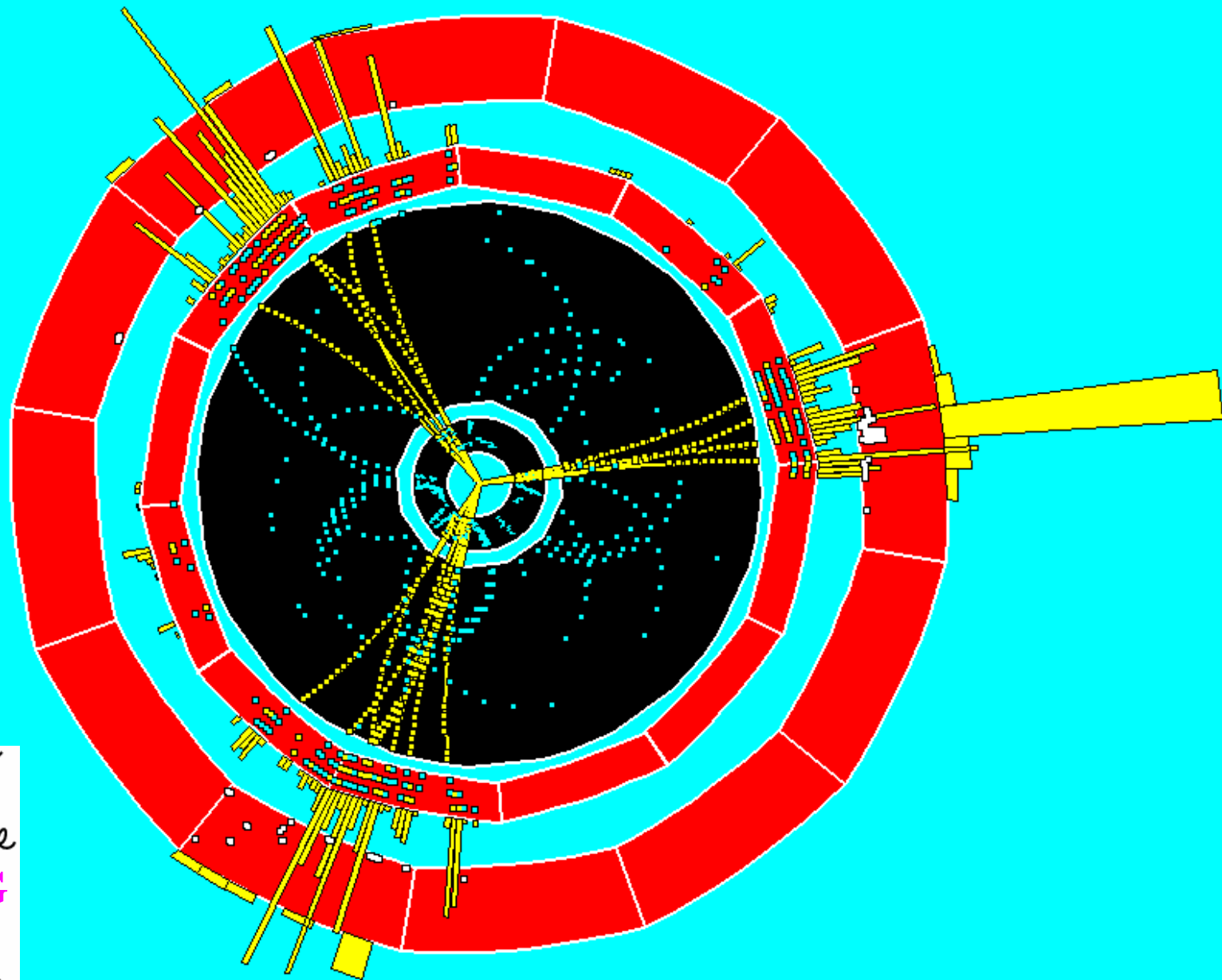

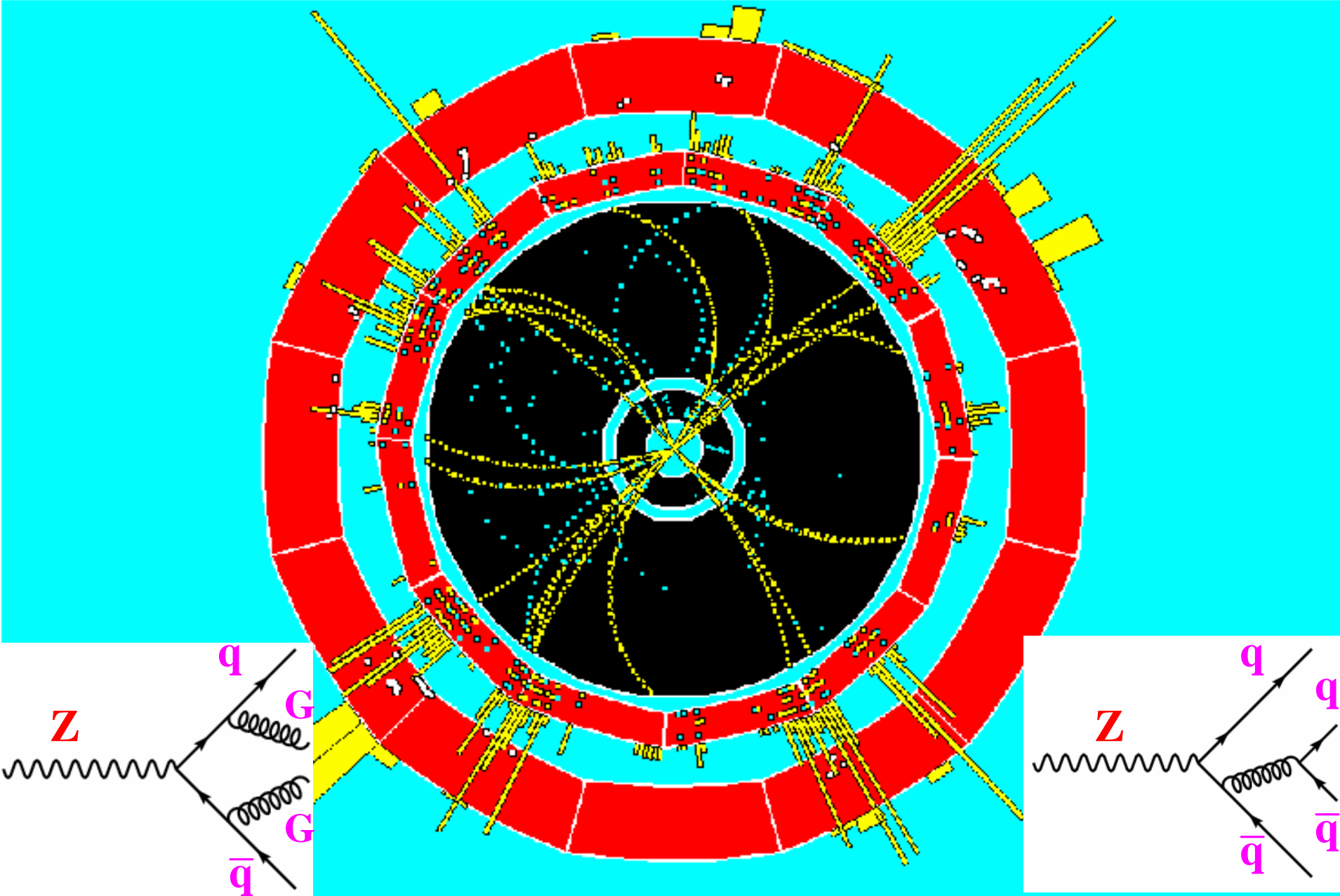

# QUANTUM CORRECTIONS

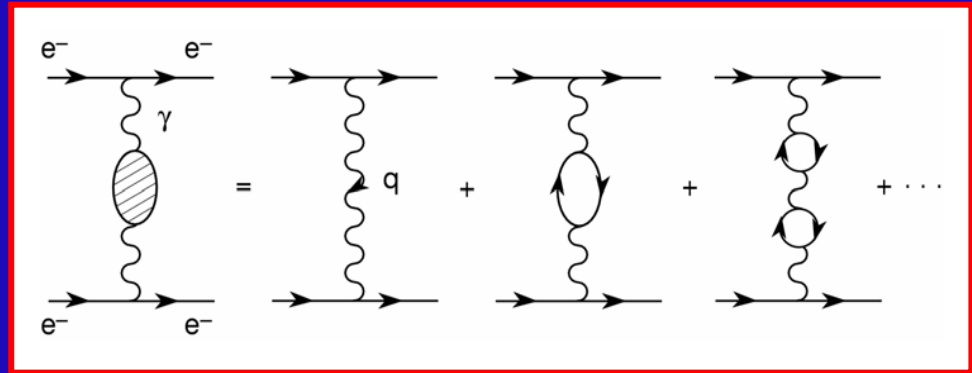

$$\mathbf{T}(Q^2) \sim \frac{\alpha}{Q^2} \left\{ 1 + \Pi(Q^2) + \Pi(Q^2)^2 + \dots \right\} \sim \frac{\alpha(Q^2)}{Q^2}$$

**Effective (Running) Coupling:**

$$\alpha(Q^2) = \frac{\alpha}{1 - \Pi(Q^2)} \approx \frac{\alpha}{1 - \frac{\alpha}{3\pi} \log\left(\frac{Q^2}{m^2}\right)}$$

**SCREENING**

$\alpha(Q^2)$  Increases with  $Q^2 \equiv -q^2$   $\longrightarrow$  Decreases at Large Distances



# VACUUM

# NO-TAN-RAFOP

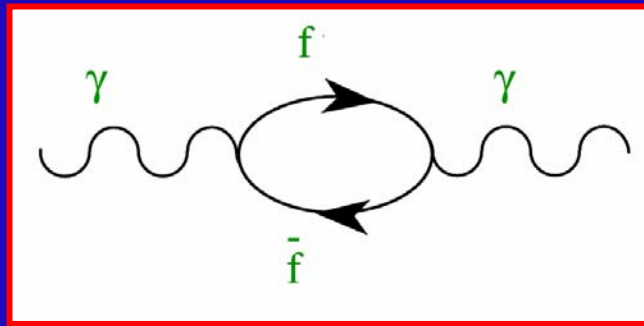

The Photon Couples to *Virtual  $f \bar{f}$  Pairs*

**Vacuum**  $\longleftrightarrow$  **Polarized Dielectric Medium**

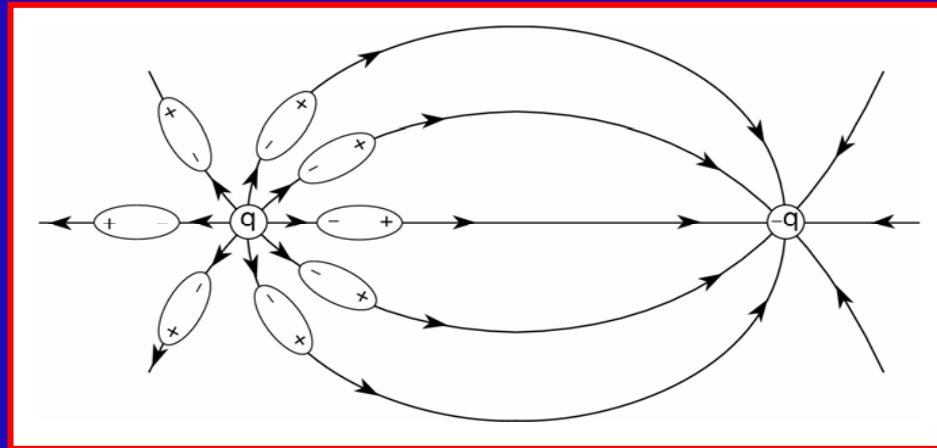

$$\alpha^{-1} = \alpha(m_e^2)^{-1} = 137.03599911 \quad (46) \quad ; \quad \alpha(M_Z^2)^{-1} = 128.95 \pm 0.05$$

( $l^- l^+$  and  $q \bar{q}$  contributions included)

# QCD RUNNING COUPLING

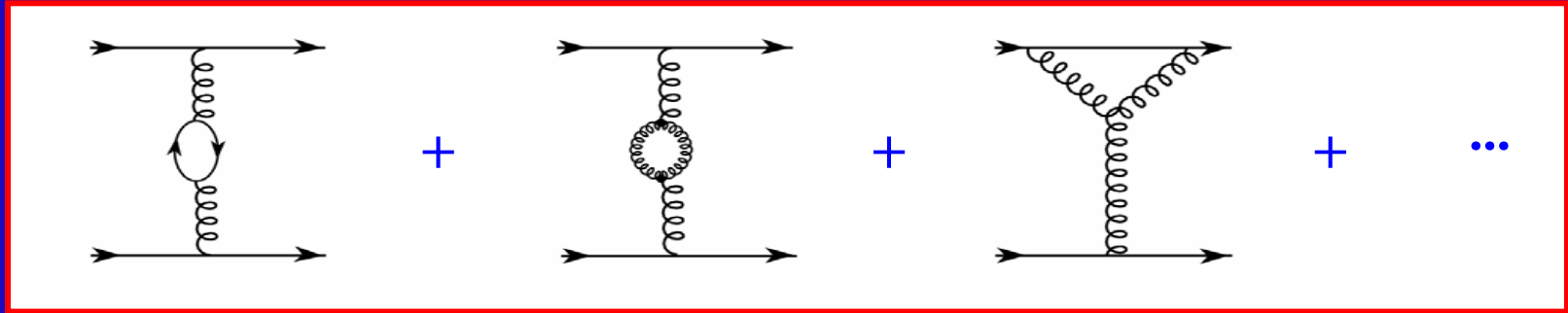

$$\alpha_s(Q^2) = \frac{\alpha_s(Q_0^2)}{1 - \beta_1 \frac{\alpha_s(Q_0^2)}{2\pi} \log\left(\frac{Q^2}{Q_0^2}\right)}$$

$$\beta_1 = \frac{1}{3} N_F - \frac{11}{6} N_C$$

quarks      gluons

$$N_C = 3, N_F = 6 \Rightarrow \beta_1 < 0 \quad ; \quad Q^2 > Q_0^2 \Rightarrow \alpha_s(Q^2) < \alpha_s(Q_0^2)$$

$\alpha_s(Q^2)$  Decreases at Short Distances

**ANTI-SCREENING**

# ASYMPTOTIC FREEDOM

$$\alpha_s(M_Z^2) = 0.119 \pm 0.002$$

$$\alpha_s(Q^2) = \frac{\alpha_s(Q_0^2)}{1 - \beta_1 \frac{\alpha_s(Q_0^2)}{2\pi} \log\left(\frac{Q^2}{Q_0^2}\right)}$$

$$\beta_1 < 0 \quad \longrightarrow \quad \lim_{Q^2 \rightarrow \infty} \alpha_s(Q^2) = 0$$

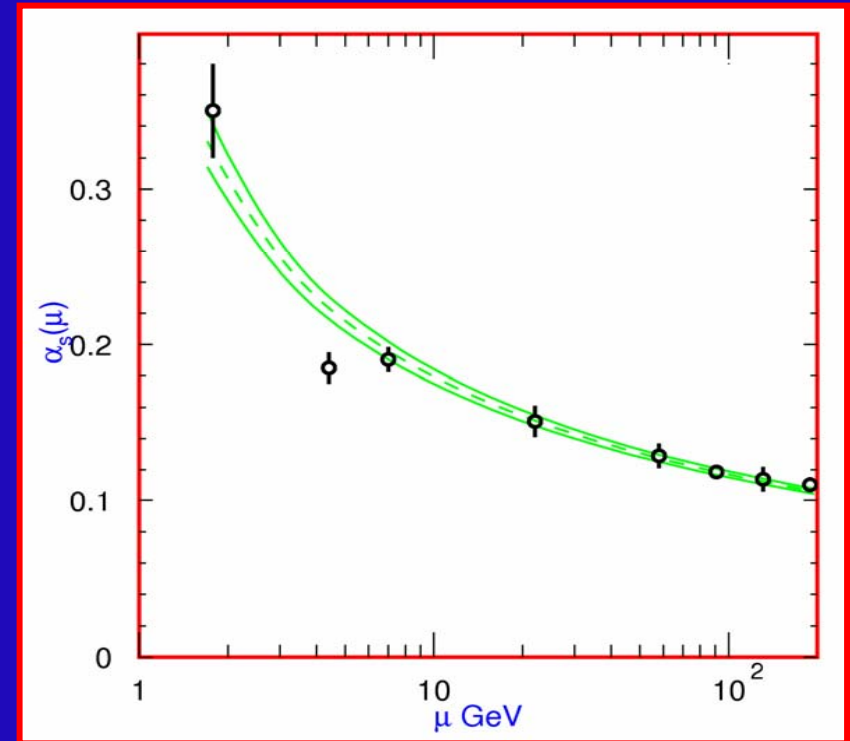

$\alpha_s(Q^2)$  increases at low energies

$\alpha_s \approx O(1)$  at 1 GeV

Non-Perturbative Region

$\longrightarrow$  CONFINEMENT ?

Confinement



Probability Hadronization = 1

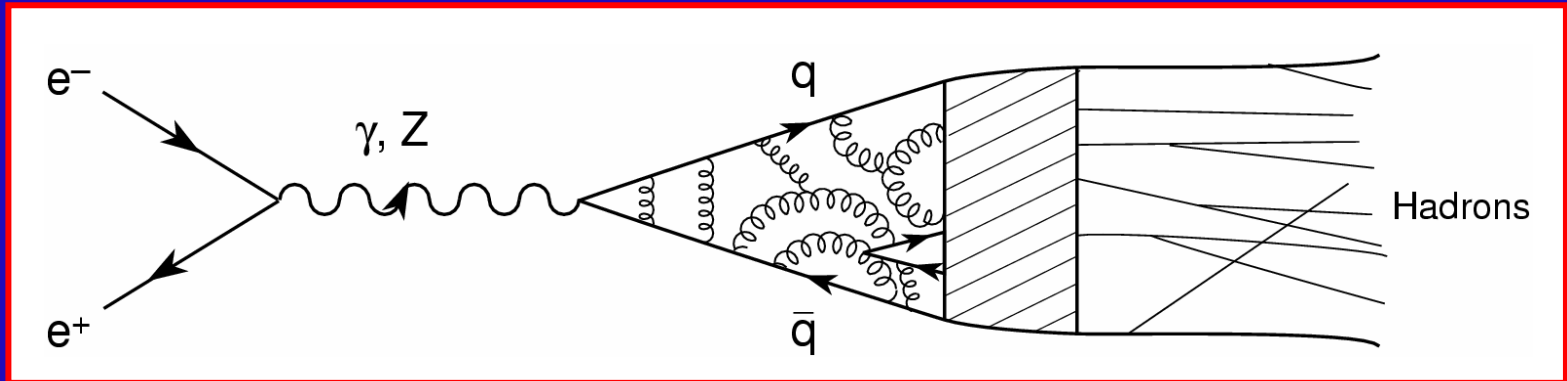

$$\sigma(e^+e^- \rightarrow \text{hadrons}) = \sigma(e^+e^- \rightarrow q\bar{q} + q\bar{q}G + q\bar{q}GG + q\bar{q}q\bar{q} + \dots)$$

$$\mathbf{T}(e^+e^- \rightarrow q\bar{q}) =$$

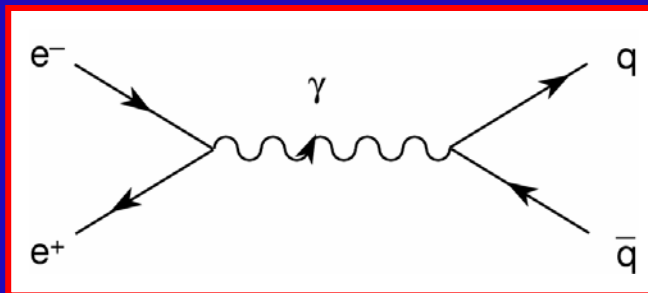

+

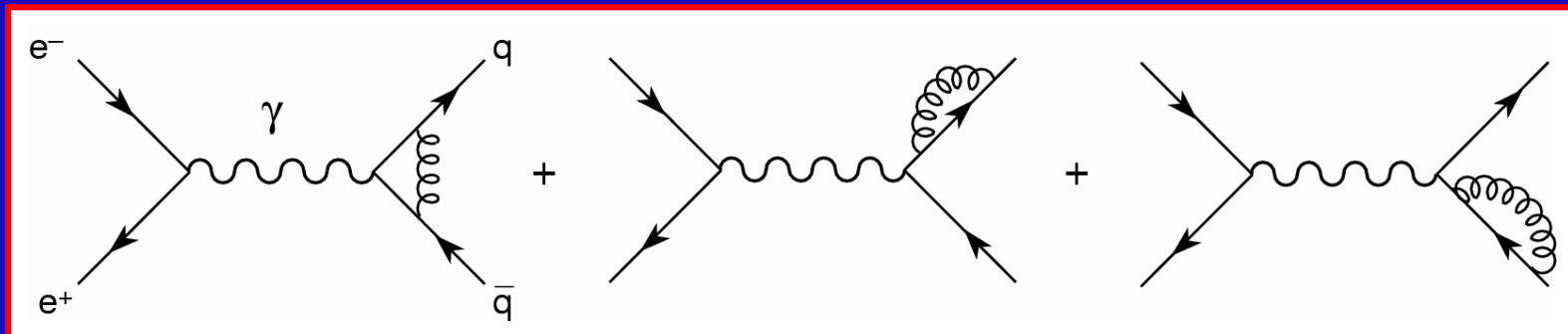

$$\mathbf{T}(e^+e^- \rightarrow q\bar{q}G) =$$

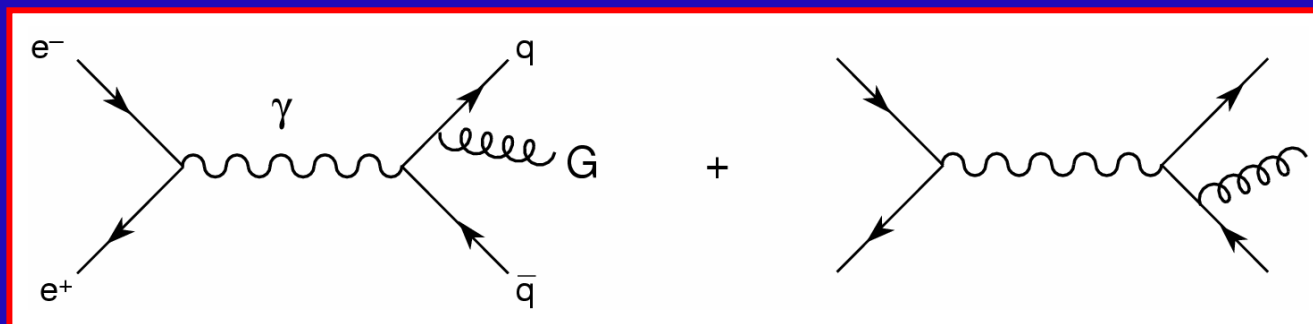

Confinement



Probability Hadronization = 1

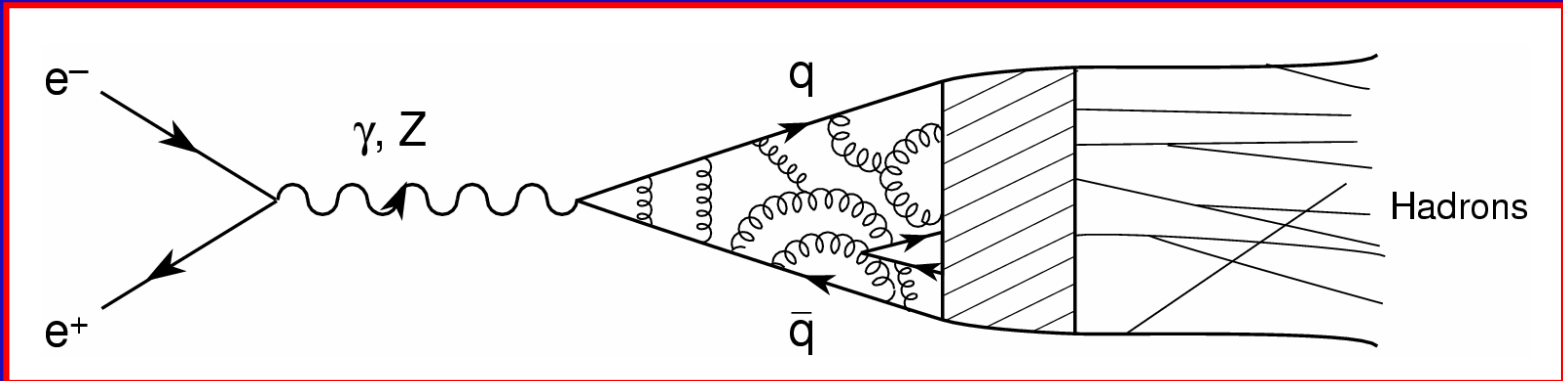

$$\sigma(e^+e^- \rightarrow \text{hadrons}) = \sigma(e^+e^- \rightarrow q\bar{q} + q\bar{q}G + q\bar{q}GG + q\bar{q}q\bar{q} + \dots)$$

$$R \equiv \frac{\sigma(e^+e^- \rightarrow \text{hadrons})}{\sigma(e^+e^- \rightarrow \mu^+\mu^-)} = \sum_q Q_q^2 N_c \left\{ 1 + \frac{\alpha_s(s)}{\pi} + \dots \right\}$$

$$R_Z \equiv \frac{\Gamma(Z \rightarrow \text{hadrons})}{\Gamma(Z \rightarrow e^+e^-)} = R_Z^{EW} N_c \left\{ 1 + \frac{\alpha_s(M_Z^2)}{\pi} + \dots \right\}$$

# $\tau^- \rightarrow \nu_\tau + \text{Hadrons}$

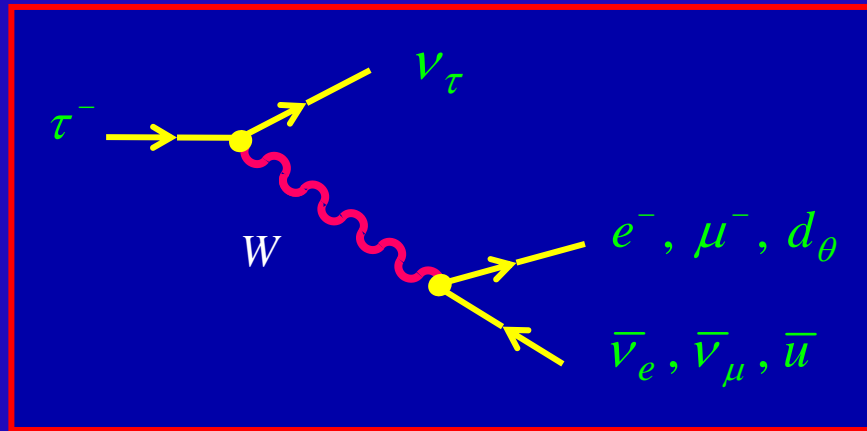

$$d_\theta = \cos \theta_C d + \sin \theta_C s$$

$$B_l \equiv \text{Br}(\tau^- \rightarrow \nu_\tau l^- \bar{\nu}_l) \approx \frac{1}{2 + N_C} = \frac{1}{5} = 20\%$$

$$B_e = (17.84 \pm 0.06)\%$$

$$B_\mu = (17.36 \pm 0.06)\%$$

**QCD:**

$$R_\tau \equiv \frac{\Gamma(\tau^- \rightarrow \nu_\tau + \text{Hadrons})}{\Gamma(\tau^- \rightarrow \nu_\tau e^- \bar{\nu}_e)} = N_C \left\{ 1 + \frac{\alpha_s(m_\tau^2)}{\pi} + \dots \right\}$$

$$R_\tau = 3.484 \pm 0.024 \quad \longrightarrow \quad \alpha_s(m_\tau^2) = 0.345 \pm 0.020 > \alpha_s(M_Z^2) = 0.119 \pm 0.002$$

# MEASUREMENTS OF $\alpha_s$

$$\alpha_s(M_Z^2) = 0.1182 \pm 0.0027$$

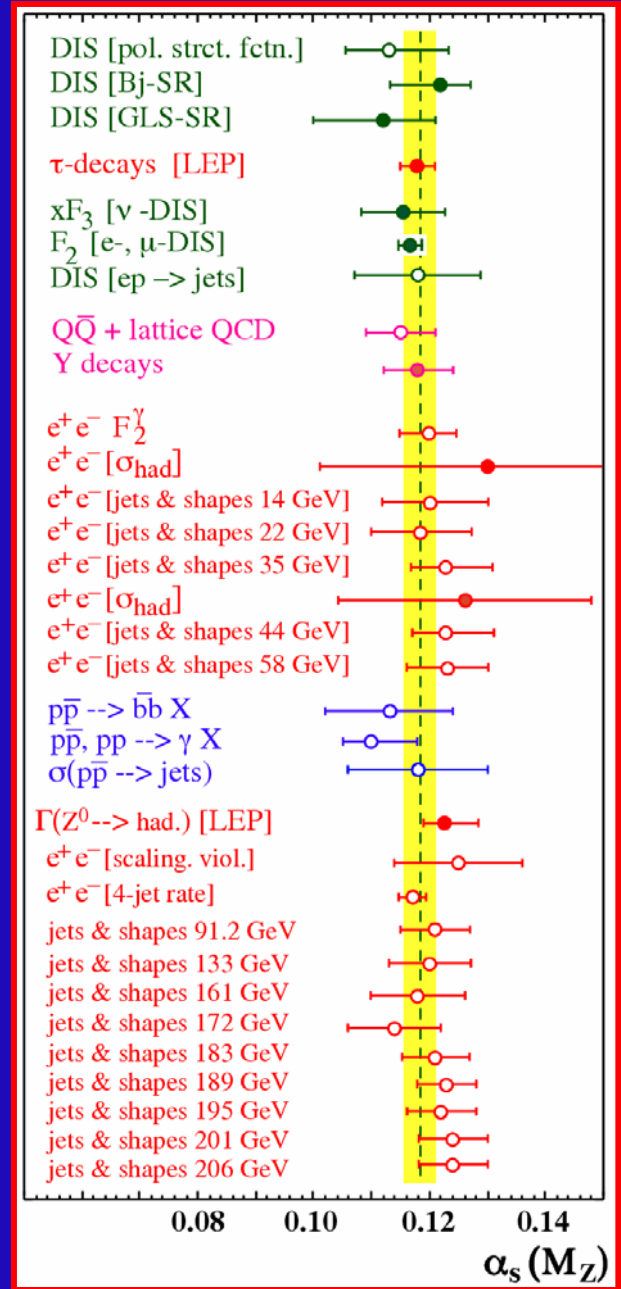
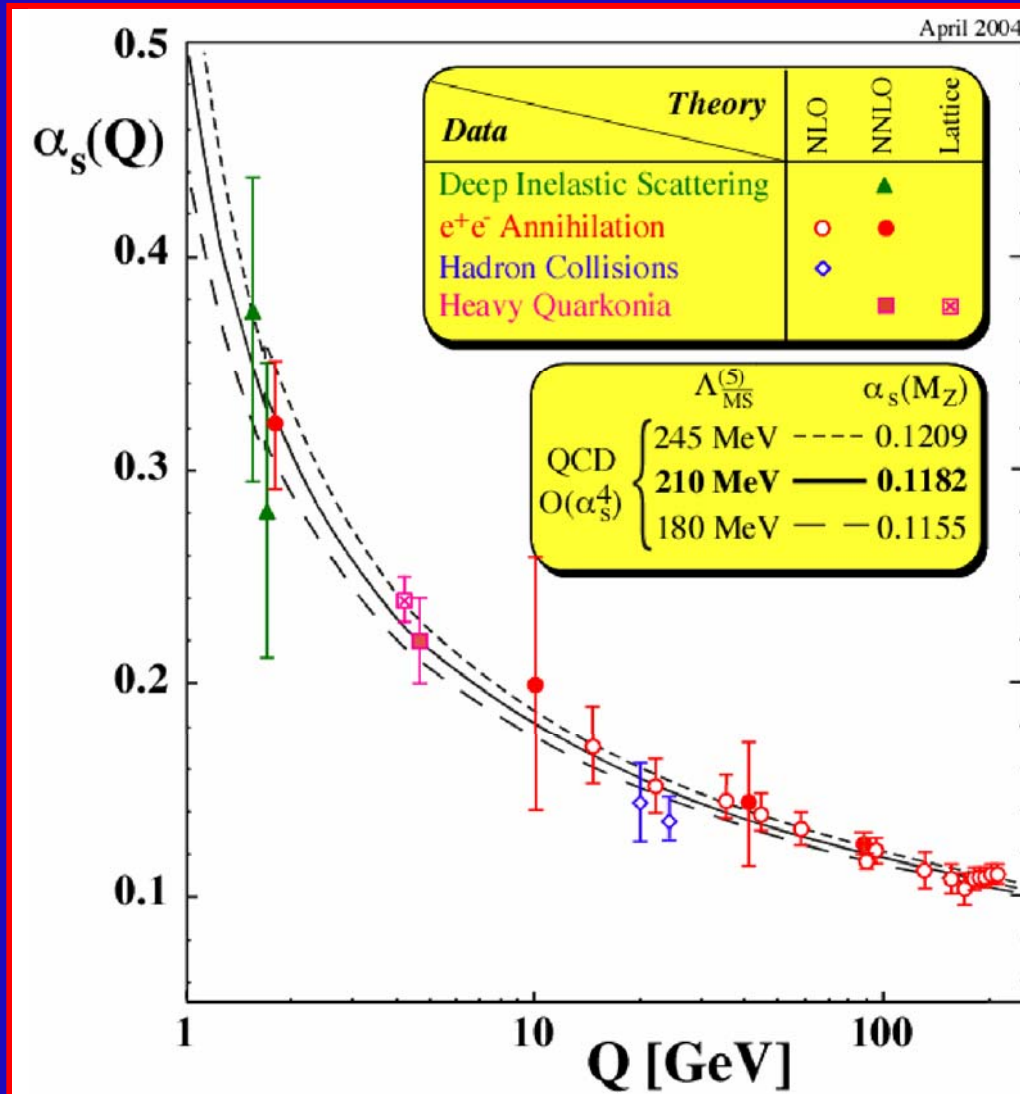



# NOBEL PRIZE IN PHYSICS 2004

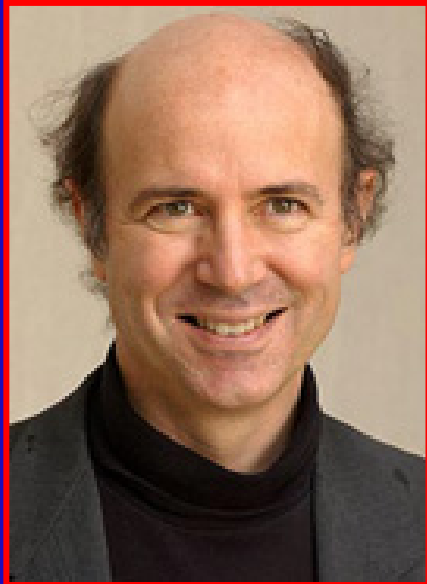

**Frank Wilczek**  
Massachusetts  
Institute of Technology



**David Gross**  
Kavli Institute  
University of California



**David Politzer**  
California  
Institute of Technology